

**LOCTEC<sup>®</sup>**

Distal Radius and Ulna Plates  
Surgical Technique



#### Disclaimer

This surgical technique is exclusively intended for medical professionals, especially physicians, and therefore may not be regarded as a source of information for non-medical persons. The description of this surgical technique does not constitute medical advice or medical recommendations nor does it convey any diagnostic or therapeutic information on individual cases. Therefore, the attending physician is fully responsible for providing medical advice to the patient and obtaining the informed consent of the patient which this surgical technique does not supersede.

The description of this surgical technique has been compiled by medical experts and trained staff of aap Implantate AG with utmost diligence and to the best of their knowledge. However, aap Implantate AG excludes any liability for the completeness, accuracy, currentness, and quality of the information as well as for material or immaterial damages arising from the use of this information.

- Introduction** ..... 2
  - Material ..... 2
  - Intended use ..... 2
  - Indications/Contraindications ..... 2
  - Processing (Sterilization & Cleaning) ..... 3
  - Features & Benefits ..... 3
- Surgical Technique** ..... 4
  - Preoperative planning ..... 4
  - Patient positioning ..... 4
  - Reduction and primary fixation ..... 4
  - Choice of implants ..... 5
- ▶ **Volar Plates** ..... 6
  - Palmar approach ..... 6
  - Insertion of plate ..... 6
  - Insertion of screws ..... 8
    - ▶ fixed angle (0°) ..... 8
    - ▶ variable angle ..... 10
  - Postoperative treatment ..... 11
- ▶ **Volar Plate XL** ..... 12
  - Palmar approach ..... 12
  - Insertion of plate ..... 12
  - Insertion of screws ..... 12
- ▶ **Straight and L-Plate (double plating)** ..... 13
  - Dorsal approach ..... 13
  - Insertion ..... 13
- ▶ **Ulna Plate** ..... 14
  - Ulnar approach ..... 14
  - Insertion ..... 14
- ▶ **Ulna Hook Plate** ..... 15
  - Ulnar approach ..... 15
  - Insertion ..... 15
- Explantation** ..... 16
- Assembly instructions screwdriver/depth gauge** ..... 17
- Implants** ..... 18
- Instruments** ..... 20
- Case Studies** ..... 22

By choosing these angular stable distal radial plates you decided for an up-to-date universal implant system. Please read the instructions for use and the surgical technique carefully before use!

The **LOQTEQ® VA Distal Radius System** combines angular stable fixation and flexibility with advanced design. Various plates have been anatomically adapted to the distal radius and the distal ulna and allow stable fixation of the most common fracture patterns and osteotomies. Multidirectional, locked plating ( $\pm 15^\circ$ ) in accordance with the "fixateur interne" principle provides permanent retention of the reduction result and promotes early functional mobilization. Narrow and broad plates in different lengths are designed for volar application, complemented by small and ulnar plates.

## Material

LOQTEQ® VA implants and instruments are manufactured using high-quality materials, which have been proven to be successful in medical technology for decades. The majority of the anatomical plates are made of pure titanium whereas the bone screws and some of the plates are made of titanium alloy. The plates are processed with a Type II anodization treatment (Dotize®). All materials employed comply with national and international standards. They are characterized by good biocompatibility, a high degree of safety against allergic reactions and good mechanical properties.

## Intended Use

The plate and screw implants of the system LOQTEQ® VA Radius 2.5 are intended for temporary fixation, correction or stabilization of the distal radius and/or distal ulna. Implants are intended for single use on human bone.

## Indications/Contraindications

### Indications

#### LOQTEQ® VA Volar Distal Radius Plate / Distal Radius Straight Plate / Distal Radius L-Plate

- Fixation of complex intra-articular and extra-articular fractures and osteotomies of the distal radius

#### LOQTEQ® VA Distal Ulna Plate / Distal Ulna Hook Plate

- Fractures and osteotomies of the distal ulna

### Contraindications

- Infection or inflammation (localized or systemic)
- Allergies against the implant material
- High risk patient for anesthesia
- Severe soft tissue swelling impacting normal wound healing
- Insufficient soft tissue coverage
- Fractures in children and adolescents with epiphyseal plates not yet ossified

In addition, the success of the operation may also be compromised by:

- Patients not cooperating and those with neurological disorders who do not wish to or cannot follow instructions given by their physician
- Past history of medical disorders or surgery on the extremity in question
- Severe chronic or acute comorbidity (such as arthritis, osteoporosis, neurogenic and vascular disorders, etc.)
- Patients not able to adhere to the rehabilitation protocol and patients for whom the success of the procedure seems unlikely (for instance, in case of dementia)
- Simple fractures of non-osteoporotic bone.

### Caution:

aap products are not approved for the spine.

### Processing (Sterilization & Cleaning)

The implants described in this surgical technique are supplied non-sterile.

Implants and instruments that are supplied in non-sterile condition must be sterilized before use. For this purpose, please refer to the Instructions for Use that are enclosed with the products.

Never use damaged implants or implants from damaged packaging.

### Features & Benefits

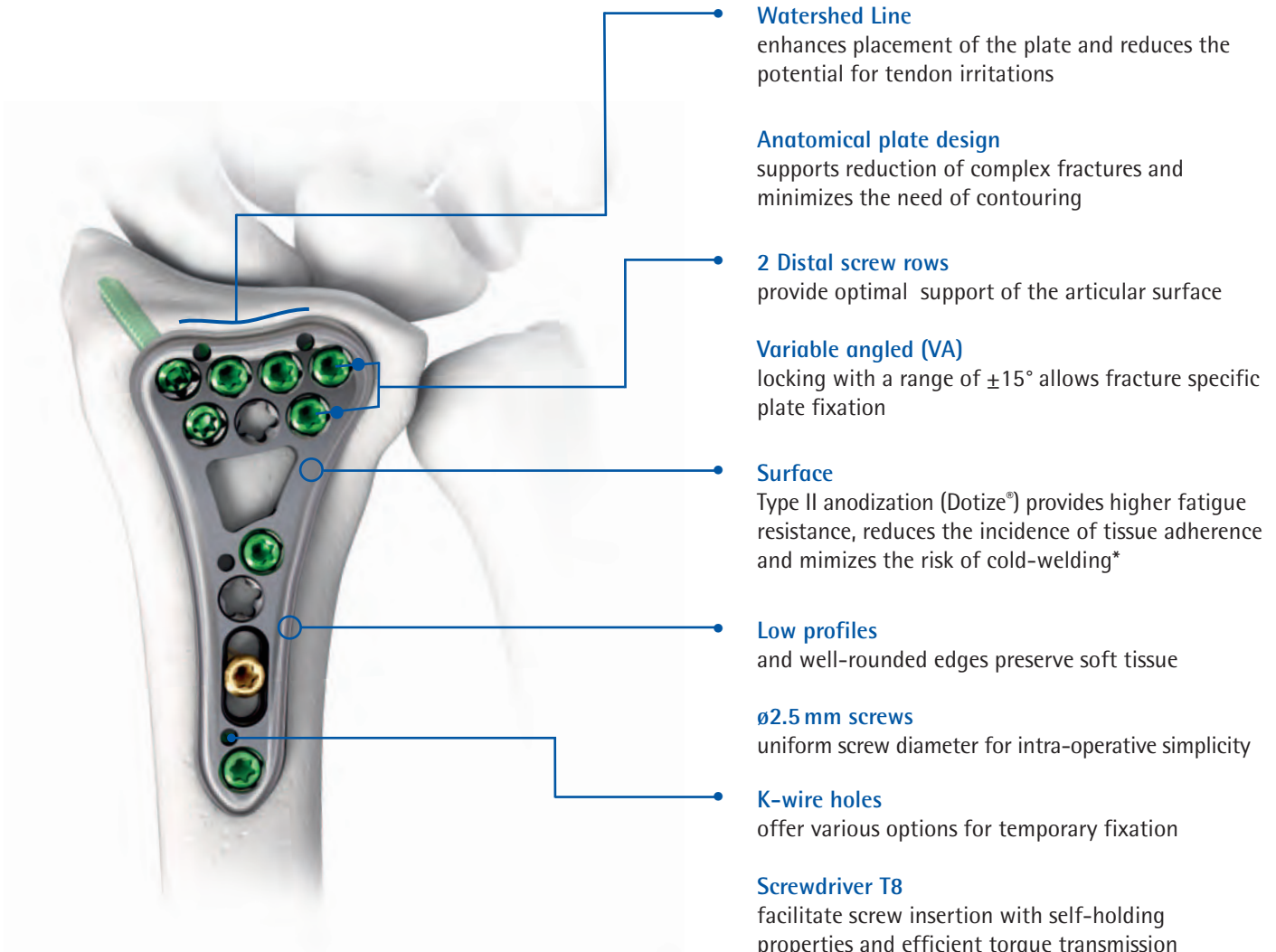

**Watershed Line**

enhances placement of the plate and reduces the potential for tendon irritations

**Anatomical plate design**

supports reduction of complex fractures and minimizes the need of contouring

**2 Distal screw rows**

provide optimal support of the articular surface

**Variable angled (VA)**

locking with a range of  $\pm 15^\circ$  allows fracture specific plate fixation

**Surface**

Type II anodization (Dotize®) provides higher fatigue resistance, reduces the incidence of tissue adherence and mimizes the risk of cold-welding\*

**Low profiles**

and well-rounded edges preserve soft tissue

**ø2.5 mm screws**

uniform screw diameter for intra-operative simplicity

**K-wire holes**

offer various options for temporary fixation

**Screwdriver T8**

facilitate screw insertion with self-holding properties and efficient torque transmission

**Plate selection**

- Volar plates in 2 widths and 3 lengths
- Volar extralong plate (XL)
- Straight and L-plates (small plates)
- Ulnar shaft plate
- Ulnar hook plate

\*DOT GmbH, Beschichtungen (F-DOTIZE-290806)

## Preoperative planning

- Evaluate fracture type and optimal plate position as well as the suitable plate using a recent X-ray. Consider the use of lag screws.
- In some cases, a CT should complement preoperative planning.

## Patient positioning

- The patient is positioned supine with the abducted arm resting on a radiolucent hand table. The supinated lower arm is draped sterile to be freely movable.
- Extension may be realized by means of Chinese finger traps on the 1st and 2nd ray (about 3-4 kg). Unless contraindicated, the procedure is performed with a pneumatic tourniquet.



## Reduction and primary fixation



- The volar radial plate can be applied as a buttress plate in flexion fractures, but may also address extension fractures.
- Fracture reduction is gradually performed with subsequent retention by locking plate fixation.

◆ **NOTE:**

With the wrist in hyper-flexion lateral fluoroscopy will aid in obtaining a precise sub-chondral position of screws in the distal fragment to the extent possible. This type of fixation ensures best purchase for the screws and helps to avoid secondary dislocation.

- Particular emphasis must be placed on restoration of the correct length correlation between radius and ulna, elimination of any steps in the radial joint surface, and compensation of any radial offset or malrotation of the distal fragment since otherwise this might restrict the post-operative range of motion. Hence, careful fracture reduction with X-ray control is crucial. K-wires or reduction forceps may help to preliminarily fixate the result of reduction, depending on the fracture pattern.

Choice of implants



- Select the plate according to fracture type and radial anatomy. Usually, bending of anatomically pre-contoured plates is neither necessary nor desirable as significant deformation of the plate holes may prevent an effective angular stable plate-screw connection. Excessive bending may also result in implant failure. Contouring the metaphyseal part of a plate is not permitted when using a targeting device.
  - Except for the oblong hole, all other plate holes can accommodate locking as well as non-locking screws with an angulation of up to 15° off-axis.
  - The tips of the screws should not protrude beyond the dorsal cortex since otherwise this might injure the extensor tendons. As the screws are supplied in 2mm increments, the ideal screw length corresponding to the measurement result may not be available. Therefore, select the screw with the next shorter length.
- ◆ **NOTE:**  
When combining locking and non-locking screws always insert the non-locking screw first, in order to pull the plate to the bone.
- Reduction technique, choice of implant, primary fixation and order of screw insertion may vary according to the fracture pattern.

## Palmar approach

- Make an incision just radial to the flexor carpi radialis tendon (FCR) approx. 7cm in length, starting at the distal wrist flexion creases. Expose the pronator quadratus muscle between the FCR tendon and the radial artery, detached from the radial contour of the distal radius, dissected and retracted ulnarly.

### ◆ NOTE:

Sparing the volar capsule of the wrist helps to avoid fragment devascularization and destabilization of volar ligaments. When retracting the soft tissues, mind the median nerve on the ulnar side as well as radial nerve and A. radialis on the radial side. Using self-retaining retractors or sharp hooks involves a risk of damaging these structures.

## Insertion of plate



### INSTRUMENTS

K-wire with trocar point,  $\varnothing$ 1.4, L 150  
 Double drill guide  $\varnothing$ 2.0/2.5  
 Twist drill  $\varnothing$ 2.0, L 110, coil 30, quick coupling  
 Depth gauge for screws  $\varnothing$ 2.5, up to L 30  
 Screwdriver T8, round handle

### ART.-NO.

NK 0014-15  
 IU 8125-00  
 IU 7420-11  
 IS 7903-30  
 IU 7808-00



- To conform different fracture types, bone dimensions and bone qualities, a choice of narrow and broad volar plates is offered to the surgeon.
- Place the plate proximal to the distal edge of the radius. Following the Watershed line, the distal part of the plate should be lower on the radial side.
- If necessary, insert K-wires  $\varnothing$ 1.4 through the plate to preliminarily fixate it. K-wire holes are in the distal and the shaft part of the plate.





- Place a non-locking cortical screw  $\varnothing 2.5$  into the oblong shaft hole using the double drill guide  $\varnothing 2.0/2.5$  (IU 8125-00) and a drill  $\varnothing 2.0$  (IU 7420-11) through the  $\varnothing 2.0$ mm side.
- Determine screw length with the depth gauge (IU 7903-30) and insert an appropriate length cortical screw (gold) with screwdriver T8 (IU 7808-00).
- Confirm plate position by fluoroscopy in A/P and lateral views. Particularly consider correct placement of the distal part of the plate and the alignment of the plate shaft. Adjust improper plate position and verify using fluoroscopy in A/P and lateral views.



## Insertion of screws

### INSTRUMENTS

Aiming device LOQTEQ® VA Radius 2.5, narrow R	ART.-NO.
Aiming device LOQTEQ® VA Radius 2.5, narrow L	IU 8172-11
Aiming device LOQTEQ® VA Radius 2.5, broad R	IU 8172-12
Aiming device LOQTEQ® VA Radius 2.5, broad L	IU 8172-21
Fixing screw for aiming block	IU 8172-22
Screwdriver T8, round handle	IU 8172-10
Screwdriver T8, round handle	IU 7808-00
Drill guide LOQTEQ® VA with scale to L 28, drill $\varnothing$ 2.0, 0°	IU 8165-22
Drill guide LOQTEQ® VA with thread, L 40, drill $\varnothing$ 2.0, 0°	IU 8165-23
Twist drill $\varnothing$ 2.0, L 110, coil 30, quick coupling	IU 7420-11
Depth gauge for screws $\varnothing$ 2.5, up to L 30	IS 7903-30

ART.-NO.
IU 8172-11
IU 8172-12
IU 8172-21
IU 8172-22
IU 8172-10
IU 7808-00
IU 8165-22
IU 8165-23
IU 7420-11
IS 7903-30

- Locking screws may be inserted fixed-angled (0°) or with variable angle. An off-center angle exceeding 15° is not recommended as it may prevent the screw from locking correctly into the plate and entail screw loosening.
- Facilitate fixed angle drilling by using an appropriate targeting device mounted onto the plate with the fixing screw (IU 8170-10).
- Engage a fixed angle drill guide (IU 8165-22 or IU 8165-23) in the selected distal plate hole and drill to the desired depth with a drill  $\varnothing$ 2.0 (IU 7420-11).

### ◆ NOTE:

The aiming devices are designed for seating fixed-angled locking screws only. Cortical screws (gold) feature a larger diameter of the head and thus can not be inserted through a mounted aiming device.

### Fixed angle (0°)



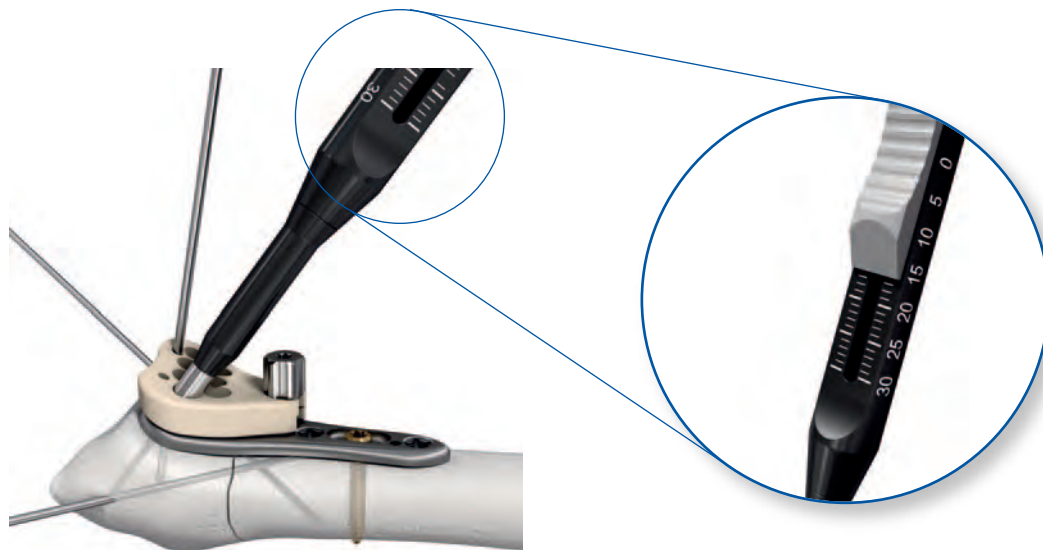

- Remove the drill guide, determine screw length with the depth gauge (IU 7903-30) and insert an appropriate length locking screw with screwdriver T8 (IU 7808-00).
- Once all distal screws have been inserted, remove the aiming device.
- Alternatively, the variable drill guide with handle (IU 8165-20) may be used.



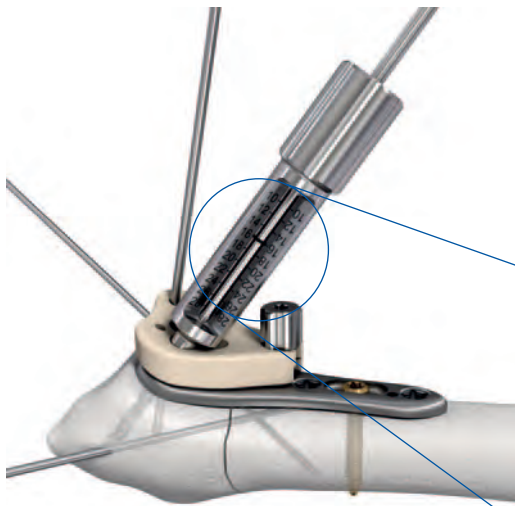

**INSTRUMENTS**

Drill guide LOQTEQ® VA with scale to L 28, drill ø2.0, 0°

**ART.-NO.**

IU 8165-22

◆ **NOTE:**

The drill guide with scale allows direct reading of the screw length aided by a marking on the drill.

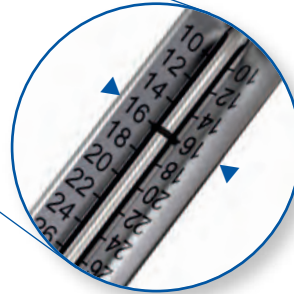

Variable angle ( $\pm 15^\circ$ )



**INSTRUMENTS**

Drill guide LOQTEQ® VA with handle, drill ø2.0, 0° to 15°  
Drill guide LOQTEQ® VA with thread, drill ø2.0, 0° to 15°

**ART.-NO.**

IU 8165-20  
IU 8165-21

- Two instruments are offered for variable angled drilling: a threaded funnel-shaped version (IU 8165-21) and a drill guide with handle (IU 8165-20) for free choice of angle.
- Engage the variable angle drill guide (IU 8165-21) in a locking plate hole and drill with a drill ø2.0 (IU 7420-11) in a chosen angle. To ensure locking the drill guide in the central axis of the plate hole (0°), avoid pressure when screwing it in.
- Mind the maximum angulation of 15° when using the variable angle drill guide with handle (IU 8165-20).





- Follow these instructions to insert further screws according to fracture pattern. It is recommended to fully accommodate the distal screw row and place screws in the second row as required. Finally, confirm all screw heads have locked flush with the plate surface.
- Pay special attention to ensure locking of the screws in the plate by exerting sufficient torque as the set does not include a torque limiter. High forces may result in cold-welding whereas insufficient forces may prevent full locking and risk subsequent screw loosening.
- Replace any locking screw that fails to lock into the plate. Among other reasons, a screw angle of more than 15° may prevent locking. Verify the result using fluoroscopy in A/P and lateral views. Exchange dorsally protruding screws for shorter ones and correct mal-positioned screws, if necessary.
- The most proximal plate hole should be preferred when securing the plate shaft with not less than 2 locking screws.
- Check the final result under fluoroscopy in A/P and lateral views.
- ◆ **NOTE:**  
After each procedure always discard single-use products, such as K-wires or drill bits marked accordingly, as well as used implants, e.g. replaced screws (see instructions for use).
- Finally close the wound.

### Postoperative treatment

- In general, the follow-up treatment is individually defined by the surgeon, and depends on fracture type and bone quality.

## Palmar approach

- For use of the XL plate extend the volar incision proximally to the extend needed.

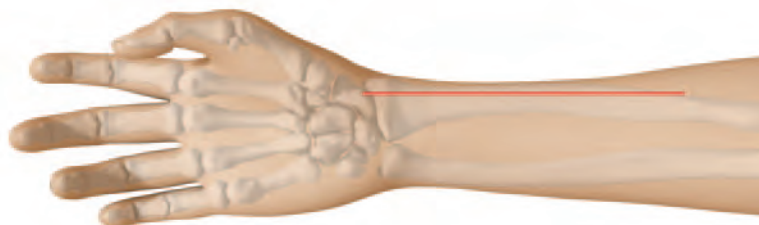

## Insertion of plate

### INSTRUMENTS

Aiming device LOQTEQ® VA Radius 2.5, narrow XL R  
 Aiming device LOQTEQ® VA Radius 2.5, narrow XL L  
 Fixing screw for aiming block  
 K-wire with trocar point, ø1.4, L 150

### ART.-NO.

IU 8172-31  
 IU 8172-32  
 IU 8172-10  
 NK 0014-15

- The distal part of the extra-long plate equals the narrow volar plate with regard to shape and screw trajectories. The plate shaft is anatomically adapted to the natural bow of the radius bone.
- Apply the plate to fit distally below the watershed line, insert a non-locking screw into the distal oblong hole and align the plate with the bone both proximally and distally.
- If necessary, use K-wires ø1.4 through the corresponding holes in the plate to preliminarily fixate it.
- Verify the plate positioning under fluoroscopy (A/P and lateral) with particular attention to alignment of the shaft and correct fit of the distal plate part. Correct the plate position if needed and check again by use of fluoroscopy (A/P and lateral).

## Insertion of screws

### INSTRUMENTS

Screwdriver T8, round handle  
 Drill guide LOQTEQ® VA with thread, drill ø2.0, 0° to 15°  
 Drill guide LOQTEQ® VA with scale to L 28, drill ø2.0, 0°  
 Drill guide LOQTEQ® VA with thread, L 40, drill ø2.0, 0°  
 Twist drill ø2.0, L 110, coil 30, quick coupling  
 Depth gauge for screws ø2.5, up to L 30

### ART.-NO.

IU 7808-00  
 IU 8165-21  
 IU 8165-22  
 IU 8165-23  
 IU 7420-11  
 IS 7903-30

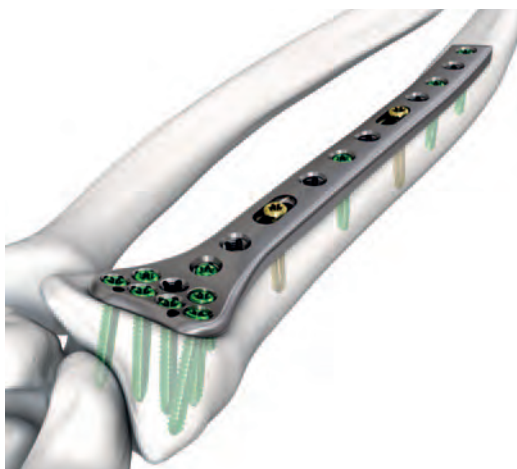

- Depending on fracture pattern and bone quality, locking or non-locking screws will be used in the plate shaft. It is recommended to use locking screws in the metaphyseal part (see insertion techniques on pages 8 to 13).
- Verify proper screw placement using fluoroscopy in A/P and lateral views. Exchange dorsally protruding screws for shorter ones and correct malpositioned screws, if necessary.
- Finally close the wound.

Dorsal approach

- Make a straight longitudinal incision over Lister's tubercle (between the second and the third dorsal compartment) with its distal end crossing the wrist crease and approximately 5-9cm in length. Expose the intermediate column via the third compartment while retracting the tendon of the extensor pollicis longus muscle (EPL).
- To ensure relocating of the EPL the distal part of the third compartment should not be opened.
- Elevate the second and fourth compartment subperiosteally to expose the fracture. Opening the second and fourth compartment is not required.

Insertion

**INSTRUMENTS**

K-wire with trocar point,  $\varnothing$ 1.4, L 150

Screwdriver T8, round handle

Drill guide LOQTEQ® VA with thread, drill  $\varnothing$ 2.0, 0° to 15°

Drill guide LOQTEQ® VA with scale to L 28, drill  $\varnothing$ 2.0, 0°

Drill guide LOQTEQ® VA with thread, L 40, drill  $\varnothing$ 2.0, 0°

Twist drill  $\varnothing$ 2.0, L 110, coil 30, quick coupling

Depth gauge for screws  $\varnothing$ 2.5, up to L 30

**ART.-NO.**

NK 0014-15

IU 7808-00

IU 8165-21

IU 8165-22

IU 8165-23

IU 7420-11

IS 7903-30

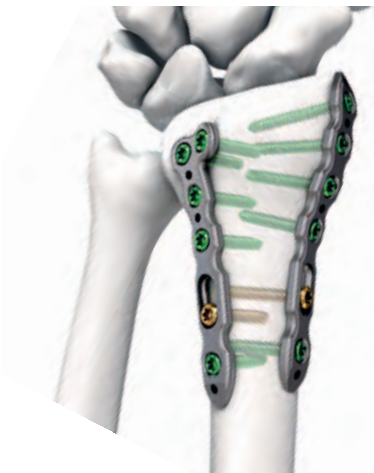

- Following fracture reduction, optionally with K-wires  $\varnothing$ 1.4, place a locking L-plate (dorso-ulnar plate) on the bone. If necessary, contour the plate to the given anatomy using the included bending pliers (IP 2506-00).
  - Place a non-locking cortical screw  $\varnothing$ 2.5 into the oblong hole for primary fixation and check the result using fluoroscopy. Fixate the plate in final position with locking screws in the previously mentioned manner (see pages 8 to 13). The order of screw insertion is adapted to the fracture pattern.
  - Then place a straight plate (dorso-radial plate) on the bone to support the radial styloid. Fixate it with a non-locking screw in the oblong hole. For fixating the plate with locking screws, use the same technique as for the L-plate. The use of non-locking screws depends on the type of fracture.
- ◆ **CAUTION:**  
Drill sleeves must not be used for bending the plates. Repeated or excessive bending should be avoided.
- ◆ **NOTE:**  
For adequate buttressing of the styloid process, the dorso-radial plate is positioned almost lateral, in an angle of 70°-90° to the dorso-ulnar plate when viewed from anterior.
- Verify proper screw placement using fluoroscopy in A/P and lateral views.
  - Finally close the wound.

## Ulnar approach

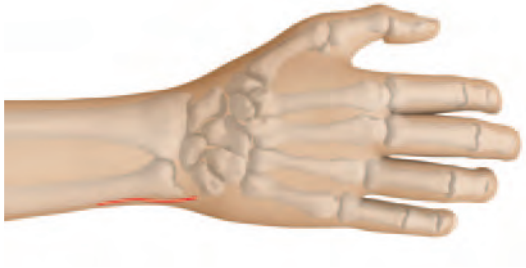

- Make an incision 1 cm dorsally and parallel to the palpable edge of the ulna approximately 5 cm in length, starting distally from the wrist creases between the extensor carpi ulnaris and the flexor carpi ulnaris tendons. Take care of the dorsal sensory branch of the ulnar nerve. After sub-periosteal dissection the fracture can be visualized, facilitated by the use of Hohmann or Langenbeck retractors. Using self-retaining retractors or sharp hooks involves a risk of damaging these structures.

## Insertion



### INSTRUMENTS

K-wire with trocar point,  $\varnothing 1.4$ , L 150

Screwdriver T8, round handle

Drill guide LOQTEQ® VA with thread, drill  $\varnothing 2.0$ ,  $0^\circ$  to  $15^\circ$

Drill guide LOQTEQ® VA with scale to L 28, drill  $\varnothing 2.0$ ,  $0^\circ$

Drill guide LOQTEQ® VA with thread, L 40, drill  $\varnothing 2.0$ ,  $0^\circ$

Twist drill  $\varnothing 2.0$ , L 110, coil 30, quick coupling

Depth gauge for screws  $\varnothing 2.5$ , up to L 30

### ART.-NO.

NK 0014-15

IU 7808-00

IU 8165-21

IU 8165-22

IU 8165-23

IU 7420-11

IS 7903-30

- Following fracture reduction, contour the ulnar shaft plate, if necessary. Depending on the fracture type, the plate will be placed ulnar or dorso-ulnar, partly or completely under the 6th compartment tendon.
- For secure fixation of the plate, 3 locking screws should be used both distally and proximally to the fracture line (see page 8 to 13).
- Verify proper screw placement using fluoroscopy in A/P and lateral views.
- Finally close the wound.



**Ulnar approach**



- Make an incision dorso-radially on the distal ulna approximately 5cm in length, starting approximately 2cm distally from the wrist creases between the extensor carpi ulnaris and the flexor carpi ulnaris tendons. Take care of the dorsal sensory branch of the ulnar nerve. After sub-periosteal dissection the fracture can be visualized, facilitated by the use of Hohmann or Langenbeck retractors. Using self-retaining retractors or sharp hooks involves a risk of damaging these structures.

**Insertion**



**INSTRUMENTS**

- K-wire with trocar point,  $\varnothing$ 1.4, L 150
- Screwdriver T8, round handle
- Drill guide LOQTEQ® VA with thread, drill  $\varnothing$ 2.0, 0° to 15°
- Drill guide LOQTEQ® VA with scale to L 28, drill  $\varnothing$ 2.0, 0°
- Drill guide LOQTEQ® VA with thread, L 40, drill  $\varnothing$ 2.0, 0°
- Twist drill  $\varnothing$ 2.0, L 110, coil 30, quick coupling
- Depth gauge for screws  $\varnothing$ 2.5, up to L 30

**ART.-NO.**

- NK 0014-15
- IU 7808-00
- IU 8165-21
- IU 8165-22
- IU 8165-23
- IU 7420-11
- IS 7903-30



- If necessary, contour the hook plate with bending pliers (IP 2506-00) to the anatomy. Grip the styloid of the distal ulna with the hooks of the plate and align plate shaft with the bone. Additional compression to the fracture will be achieved by drilling off-centre in a proximal direction in the oblong hole. Primary stabilization of the ulnar styloid with a K-wire between the hooks may be carefully performed as it involves a risk of further fracturing the small fragment.

**◆ NOTE:**

**Avoid extensive surgical exposure of the ulnar head as this may damage essential soft tissue stabilizers and effect an instable radio-ulnar joint.**

- Fixate the plate with a non-locking screw  $\varnothing$ 2.5 in the oblong hole and check the positioning using fluoroscopy in A/P and lateral views.
- 3 distal screws should be inserted mono-cortically to avoid protruding the second cortex and projecting into the distal radio-ulnar or ulnar radio-carpal joint. Then secure the plate with screws from distal to proximal in the previously mentioned manner (see pages 8 to 13).
- Verify proper screw placement using fluoroscopy in A/P and lateral views.
- Finally perform wound closure

**INSTRUMENTS**

Explantation screwdriver T8, round handle

**ART.-NO.**

IU 7811-08



◆ **NOTE:**

For safe screw removal, use the appropriate explantation screwdriver T8 (IU 7811-08). Explantation screwdrivers are not self-retaining and allow for higher torque transmission during screw removal. They should be ordered separately.

The screwdrivers T8 in the set (IU 7808-00) are self-retaining and should not be used for screw removal.

- Place an incision on the old scar. Manually unlock all locking screws and sequentially remove them.

Screwdriver T8

The rotating cap of the screwdriver handle enables secure and easy insertion of screws. For cleaning purposes it must be removed.

Disassembly

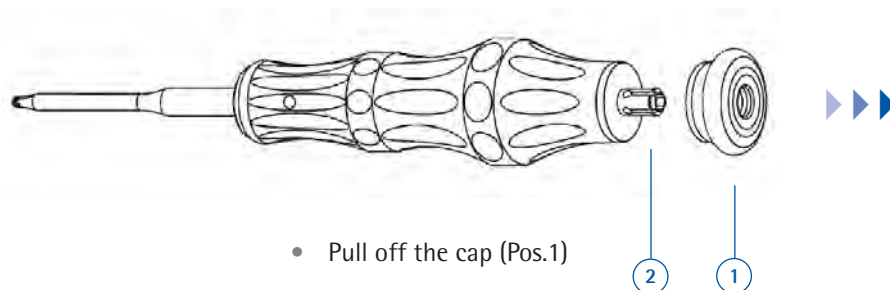

- Pull off the cap (Pos.1)

Assembly

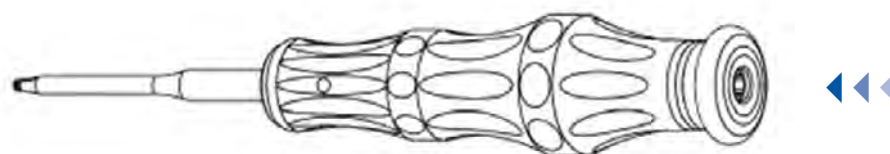

- Put on the cap (Pos. 2)

Depth gauge for screws  $\varnothing 2.5$

Disassembly

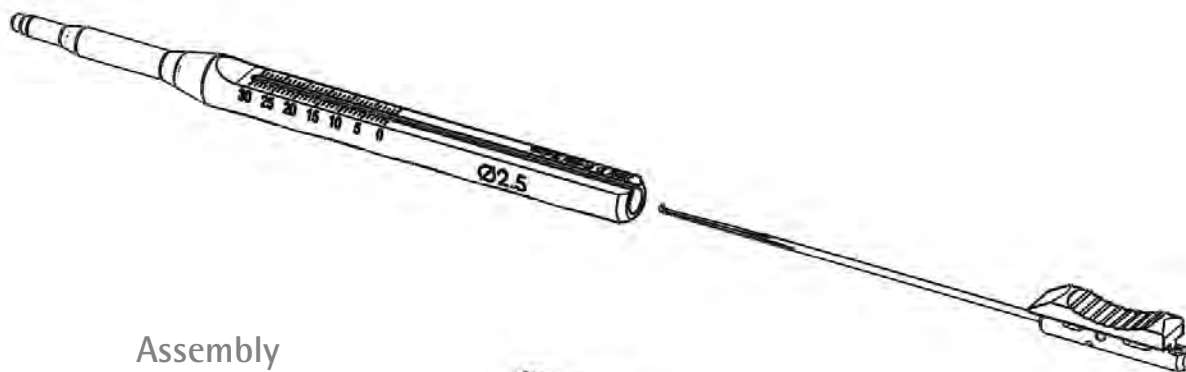

Assembly

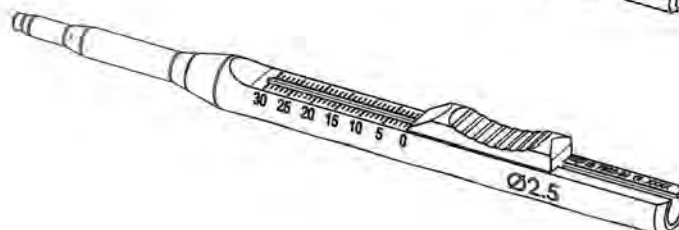



### LOQTEQ® VA Volar Distal Radius Plate 2.5, narrow

HOLES	LENGTH (mm)	WIDTH HEAD (mm)	LEFT	RIGHT
3	46	22	PR 2512-03-2	PR 2511-03-2
4	54	22	PR 2512-04-2	PR 2511-04-2
5	62	22	PR 2512-05-2	PR 2511-05-2



Aiming device LOQTEQ® VA Radius 2.5, narrow R	IU 8172-11
Aiming device LOQTEQ® VA Radius 2.5, narrow L	IU 8172-12
Fixing screw for aiming device	IU 8172-10



### LOQTEQ® VA Volar Distal Radius Plate 2.5, broad

HOLES	LENGTH (mm)	WIDTH HEAD (mm)	LEFT	RIGHT
3	46	26	PR 2522-03-2	PR 2521-03-2
4	54	26	PR 2522-04-2	PR 2521-04-2
5	62	26	PR 2522-05-2	PR 2521-05-2



Aiming device LOQTEQ® VA Radius 2.5, broad R	IU 8172-21
Aiming device LOQTEQ® VA Radius 2.5, broad L	IU 8172-22
Fixing screw for aiming device	IU 8172-10



### LOQTEQ® VA Volar Distal Radius Plate 2.5, narrow, XL

HOLES	LENGTH (mm)	WIDTH HEAD (mm)	LEFT	RIGHT
11	120	22	PR 2512-11-2	PR 2511-11-2



Aiming device LOQTEQ® VA Radius 2.5, XL R	IU 8172-31
Aiming device LOQTEQ® VA Radius 2.5, XL L	IU 8172-32
Fixing screw for aiming device	IU 8172-10



### LOQTEQ® VA Distal Radius Straight Plate 2.5

HOLES	LENGTH (mm)	WIDTH HEAD (mm)	LEFT	RIGHT
6	58	7	PR 2540-06-2	



### LOQTEQ® VA Distal Radius L-Plate 2.5

HOLES	LENGTH (mm)	WIDTH HEAD (mm)	LEFT	RIGHT
2/4	49	7	PR 2542-06-2	PR 2541-06-2



LOQTEQ® VA Distal Radius Ulna Plate 2.5

HOLES	LENGTH (mm)	WIDTH HEAD (mm)	
8	46	13,2	PR 2545-08-2



LOQTEQ® VA Distal Radius Ulna Hook Plate 2.5

HOLES	LENGTH (mm)	WIDTH HEAD (mm)	
6	42	6	PR 2550-06-2

LOQTEQ® VA  
Cortical Screw 2.5, T8



L 10	SK 2530-10-2
L 12	SK 2530-12-2
L 14	SK 2530-14-2
L 16	SK 2530-16-2
L 18	SK 2530-18-2
L 20	SK 2530-20-2
L 22	SK 2530-22-2
L 24	SK 2530-24-2
L 26	SK 2530-26-2
L 28	SK 2530-28-2

Cortical Screw 2.5,  
small head, T8, self-tapping



L 10	SK 2512-10-2
L 12	SK 2512-12-2
L 14	SK 2512-14-2
L 16	SK 2512-16-2
L 18	SK 2512-18-2
L 20	SK 2512-20-2
L 22	SK 2512-22-2
L 24	SK 2512-24-2

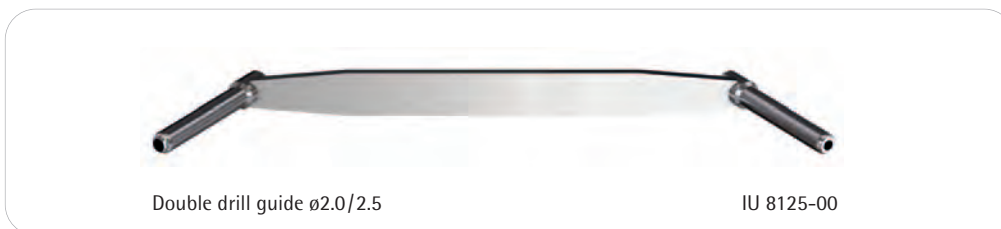
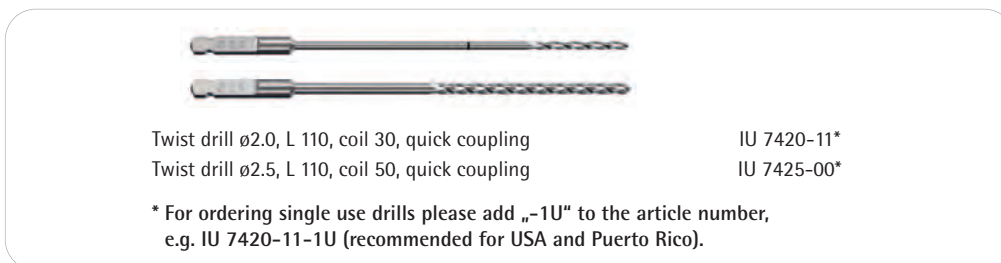
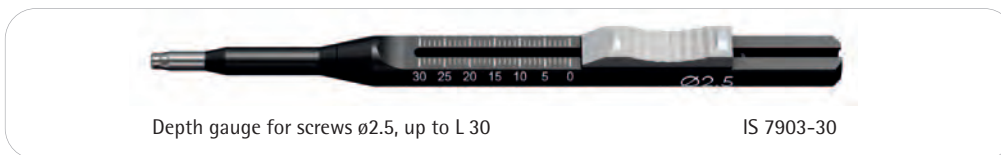
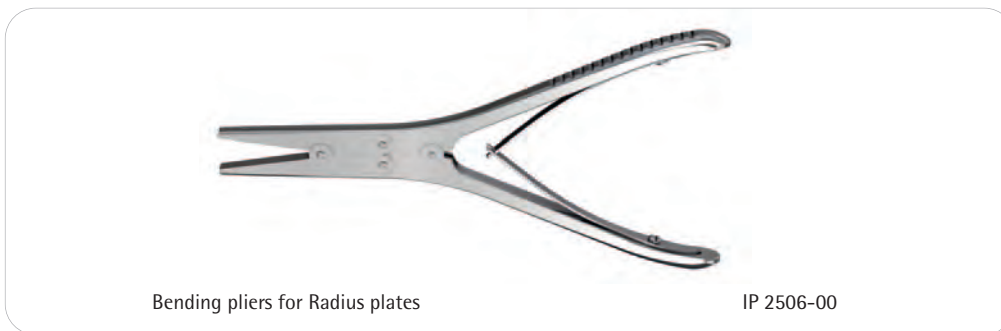

Handle quick coupling, with torque limiter 1.5 Nm

IU 7707-15



Drill guide LOQTEQ® VA with handle, drill ø2.0, 0° to 15° IU 8165-20



Drill guide LOQTEQ® VA with thread, drill ø2.0, 0° to 15° IU 8165-21



Drill guide LOQTEQ® VA with scale to L 28, drill ø2.0, 0° IU 8165-22



Drill guide LOQTEQ® VA with thread, L 40, drill ø2.0, 0° IU 8165-23



Drill guide LOQTEQ® VA with thread, L 50, drill ø2.0, 0° IU 8165-24

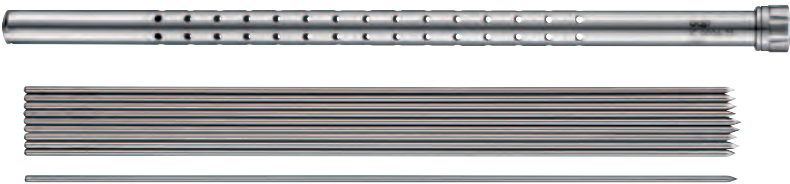

Caddy for K-wire L 150 IC 0006-15  
 K-wire with trocar point, ø1.4, L 150 NK 0014-15

## C1 Fracture, supply with Volar (broad) and Ulna Hook Plate

Preoperative



Postoperative



Clinical case and CT images with the kind permission of  
Clinic and Polyclinic of Trauma, Hand and Reconstructive Surgery  
University Hospital Gießen and Marburg, Germany

C1 Fracture, supply with Volar Plate (broad)

Preoperative



Postoperative



Clinical case and CT images with the kind permission of  
 Clinic and Polyclinic of Trauma, Hand and Reconstructive Surgery  
 University Hospital Gießen and Marburg, Germany



Subject to technical modifications,  
errors and misprints.

© aap Implantate AG  
WP 50P040 US / 2005-1

Layout, typesetting:  
deSIGN graphic - Wolfram Passlack

Illustrations:  
Pixelmolkerei

**aap Implants Inc.**  
260 Peachtree Street NW • Suite 2200  
Atlanta • GA 30303 USA  
Phone +1 678-942-3791  
e-Fax +1 877-373-0637  
[aapcs@gmlx.us.com](mailto:aapcs@gmlx.us.com)  
[www.aap-implants.com](http://www.aap-implants.com)

# LOCTEC®

---



**aap Implants Inc.**  
260 Peachtree Street NW • Suite 2200  
Atlanta • GA 30303 USA

Phone +1 678-942-3791  
e-Fax +1 877-373-0637

[aaps@gmx.us.com](mailto:aaps@gmx.us.com)  
[www.aap-implants.com](http://www.aap-implants.com)